

**PORTATA
FLOW RATE**

**40 lt/min
10.56 gpm**

**PRESSIONE MINIMA
MIN PRESSURE**

**3 Bar
43.51 Psi**

**PRESSIONE MASSIMA
MAX PRESSURE**

**500 Bar
7251.89 Psi**

**RENDIMENTO
PERFORMANCE**

**135.000 Kcal/h
536.000 BTU → 128 Kw**

**CONSUMO DIESEL
DIESEL CONSUMPTION**

13.23 lt/h

Consumo stimato calcolat alla pressione del gasolio di 13.5 bar
Estimated consumption calculated at the diesel pressure of 13.5 bar



Codice Code	Bar	Psi	Lt/min	Gpm	m	ft	Serpentina / Serpentine		Ugello Diesel Nozzle	Elettrovalvola Electrovalve	Motore Motor Volts-Hz	Peso netto Net weight	
							Tubo / Pipe Spessore / Thickness	Ø				Kg	Lbs
3.026.02.116	500	7251.89	40	10.56	48	157	2.77**	1/2"	3.5	24V AC*	230V (50)	105	230
3.026.02.117	500	7251.89	40	10.56	48	157	2.77**	1/2"	3.5	12V DC	12V	105	230
3.026.02.118	500	7251.89	40	10.56	48	157	2.77**	1/2"	3.5	24V DC	24V	105	230

PACKAGING

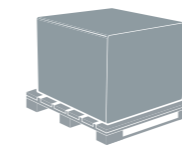

PEZZI PER PALLET / PIECES EACH PALLET	CM	INCH	KG	LBS
1	66X80X132	25.9X31.4X51.96	121	267
2	120X80X132	47.2X31.4X51.96	240	527

DIMENSIONI / DIMENSIONS

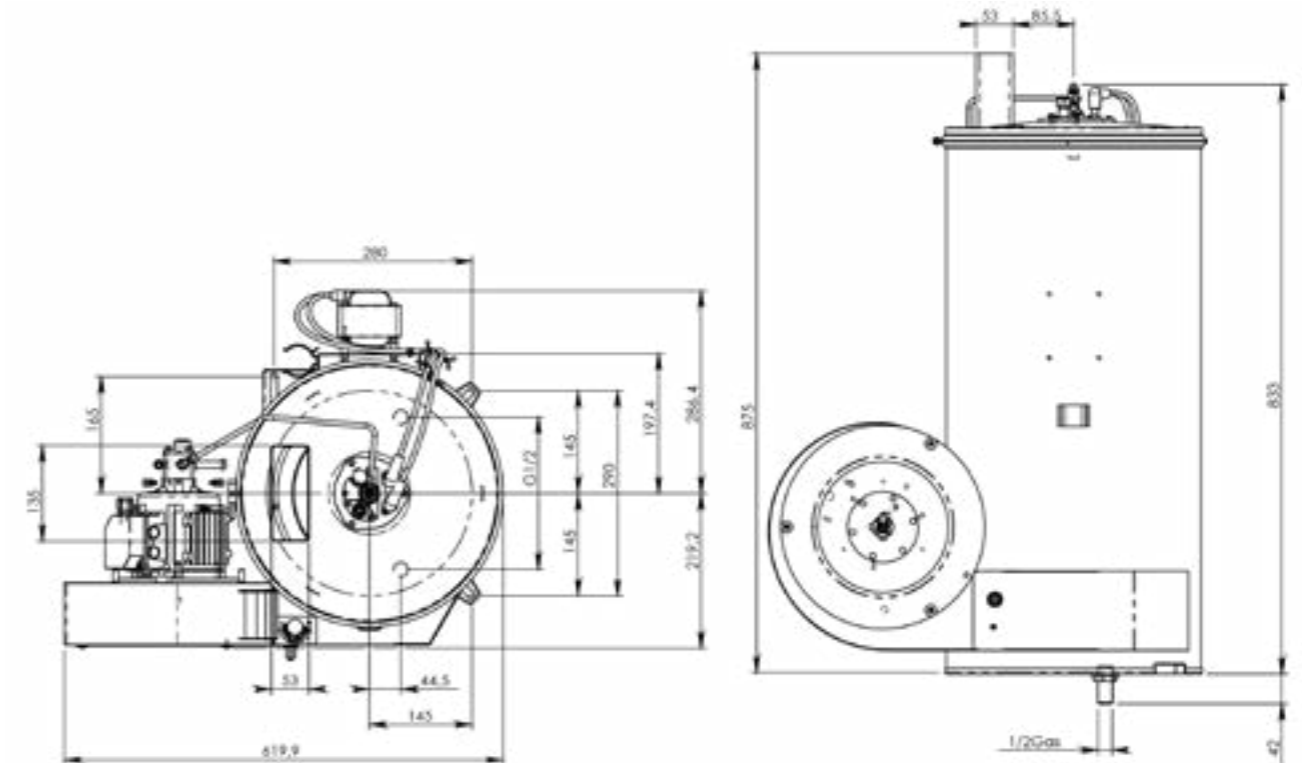

NOTE / NOTES



Caldai con pressioni o portata diversa su richiesta
On demand heaters with different pressures or flow

NOTE / NOTES

COLLETTORE PORTA Sonda TERMOSTATO A RICHIESTA HOUSING FOR THERMOSTAT ON DEMAND

* A richiesta possono essere fornite elettrovalvole a 12V DC - 24V DC - 220V AC - 24V AC

* On demand: 12V DC - 24V DC - 220V AC - 24V AC electrovalves are available

DC: Corrente continua / DC current

AC: Corrente alternata / AC current

** Serpentina senza saldatura / Coil without welding